

LEGEND MODEL T-303 IBM gate valves are made of ASTM A-126, Class B cast iron with bronze trim. They are an outside screw and yoke (OS & Y) design with a bolted bonnet and ANSI Class 125 flanged ends. They have a solid wedge with replaceable seat rings and meet MSS-SP70 specifications. They are designed for use in commercial and industrial applications for water, steam, gases and other general piping requirements.

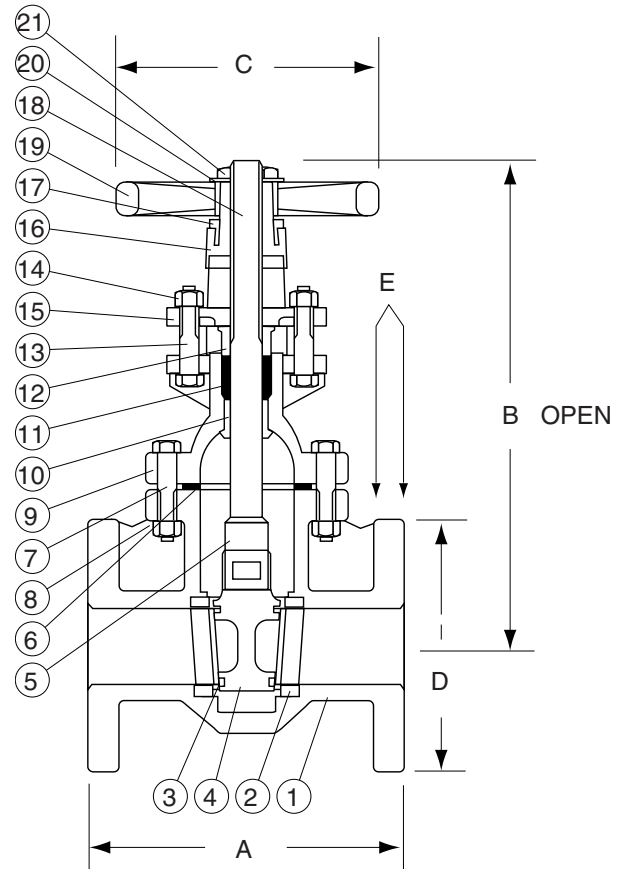

MODEL T-303
PRESSURE RATING
200 W.O.G. NON-SHOCK
125 W.S.P. TO 450°F



MATERIAL SPECIFICATIONS			
NO.	PART	MATERIAL	ASTM
1	BODY	CAST IRON	A126 CLASS B
2	SEAT RING	BRONZE	B62
3	WEDGE FACE RING	BRONZE	B62
4	WEDGE	CAST IRON	A126 CLASS B
5	STEM	BRASS	B16
6	BODY GASKET	GRAPHITE	
7	BODY BOLT	STEEL	A307
8	BODY NUT	STEEL	A307
9	BONNET	CAST IRON	A126 CLASS B
10	BACKSEAT BUSHING	BRASS	B16
11	PACKING	GRAPHITE	
12	PACKING GLAND	BRASS	B16
13	GLAND FOLLOWER BOLT	STEEL	A307
14	GLAND FOLLOWER NUT	STEEL	A307
15	GLAND FOLLOWER	DUCTILE IRON	A536
16	YOKE BUSHING	BRONZE	B62
17	YOKE BUSHING NUT	CAST IRON	A126 CLASS B
18	SCREW	STEEL	A307
19	HANDWHEEL	CAST IRON	A126 CLASS B
20	IDENTIFICATION PLATE	ALUMINUM	
21	HANDWHEEL NUT	DUCTILE IRON	A536

DIMENSIONS IN INCHES					
SIZE	A	B	C	D	E
2"	7.0	13.75	7.0	6.0	.625
2½"	7.5	15.375	7.0	7.0	.6875
3"	8.0	17.875	8.0	7.5	.75
4"	9.0	22.125	10.0	9.0	.9375
5"	10.0	26.0	10.0	10.0	.9375
6"	10.5	30.75	12.0	11.0	1.0
8"	11.5	36.625	14.0	13.5	1.125

LEGEND MODEL T-301 IBM gate valves are made of ASTM A-126, Class B cast iron with bronze trim. They are a non-rising stem design with a bolted bonnet and ANSI Class 125 flanged ends. They have a solid wedge with replaceable seat rings and meet MSS-SP70 specifications. They are designed for use in commercial and industrial applications for water, steam, gases and other general piping requirements.



**MODEL
T-301**

PRESSURE RATING
200 W.O.G. NON-SHOCK
125 W.S.P. TO 450°F

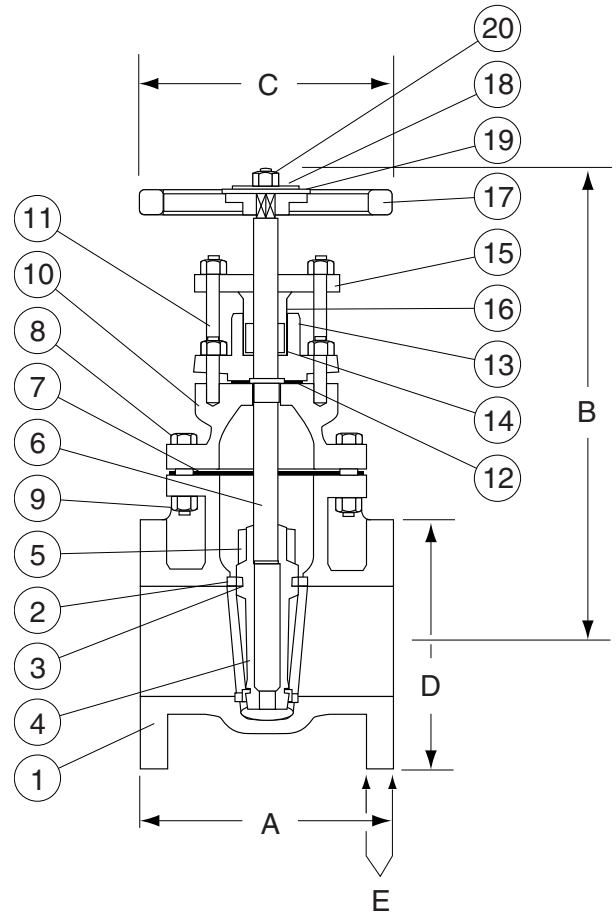

MATERIAL SPECIFICATIONS

NO.	PART	MATERIAL	ASTM
1	BODY	CAST IRON	A126 CLASS B
2	SEAT RING	BRONZE	B62
3	WEDGE FACE RING	BRONZE	B62
4	WEDGE	CAST IRON	A126 CLASS B
5	WEDGE BUSHING	BRONZE	B62
6	STEM	BRASS	B16
7	BODY GASKET	GRAPHITE	
8	BODY BOLT	STEEL	A307
9	BODY NUT	STEEL	A307
10	BONNET	CAST IRON	A126 CLASS B
11	GLAND FOLLOWER BOLT	STEEL	A307
12	STUFFING BOX GASKET	GRAPHITE	
13	STUFFING BOX	CAST IRON	A126 CLASS B
14	PACKING	GRAPHITE	
15	GLAND FOLLOWER	DUCTILE IRON	A536
16	PACKING GLAND	BRASS	B16
17	HANDWHEEL	CAST IRON	A126 CLASS B
18	IDENTIFICATION PLATE	ALUMINUM	
19	WASHER	STEEL	A307
20	HANDWHEEL NUT	STEEL	A307



DIMENSIONS IN INCHES

SIZE	A	B	C	D	E
2"	7.0	11.0	7.0	6.0	.625
2½"	7.5	12.5	7.0	7.0	.6875
3"	8.0	13.125	8.0	7.5	.75
4"	9.0	15.250	10.0	9.0	.9375
5"	10.0	17.8125	10.0	10.0	.9375
6"	10.5	19.75	12.0	11.0	1.0
8"	11.5	25.0	14.0	13.5	1.125

LEGEND MODEL T-311 IBM check valves are made of ASTM A-126, Class B cast iron with bronze trim. They have a bolted bonnet with replaceable seat rings and hanger pin. They have a solid wedge design with ANSI Class 125 flanged ends and meet MSS-SP71, Type 1 specifications. They are designed for use in commercial and industrial applications for backflow prevention. Can be installed vertically or horizontally.



MODEL T-311

PRESSURE RATING
 200 W.O.G. NON-SHOCK
 125 W.S.P. TO 450°F

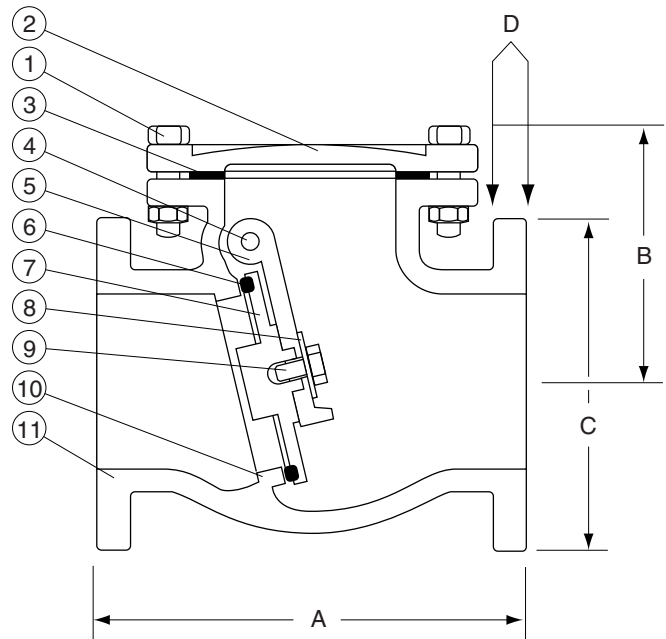

MATERIAL SPECIFICATIONS

NO.	PART	MATERIAL	ASTM
1	COVER BOLT & NUT	STEEL	A307
2	COVER	CAST IRON	A126 CLASS B
3	GASKET	NON-ASBESTOS	
4	HANGER PIN	STAINLESS STEEL	
5	HANGER	CAST IRON	A126 CLASS B
6	DISC RING	BRONZE	B62
7	DISC	CAST IRON	A126 CLASS B
8	DISC WASHER	STEEL	A307
9	DISC BOLT	STEEL	A307
10	SEAT RING	BRONZE	B62
11	BODY	CAST IRON	A126 CLASS B

DIMENSIONS IN INCHES

SIZE	A	B	C	D
2"	8.0	4.0	6.0	.625
2½"	8.5	4.5	7.0	.6875
3"	9.5	5.125	7.5	.75
4"	11.5	6.125	9.0	.9375
5"	13.0	6.8125	10.0	.9375
6"	14.0	8.0	11.0	1.0
8"	19.5	9.4375	13.5	1.125

LEGEND MODEL T-19 flanged y-strainers are made of high tensile strength ASTM A126-B cast iron. The perforated strainer is .304 stainless steel. Ideally suited for water, oil, gas and steam applications. They are an economical method of protecting vital mechanical devices. The closure plug is furnished.



**MODEL
T-19**

PRESSURE RATING

200 W.O.G. NON-SHOCK
150 W.S.P. TO 450°F

FEATURES

- IRON BODY
- FLANGED ENDS
- CLOSURE PLUG FURNISHED
- 1/16" PERFORATED STRAINER (2"- 4")
- 1/8" PERFORATED STRAINER (5"- 8")

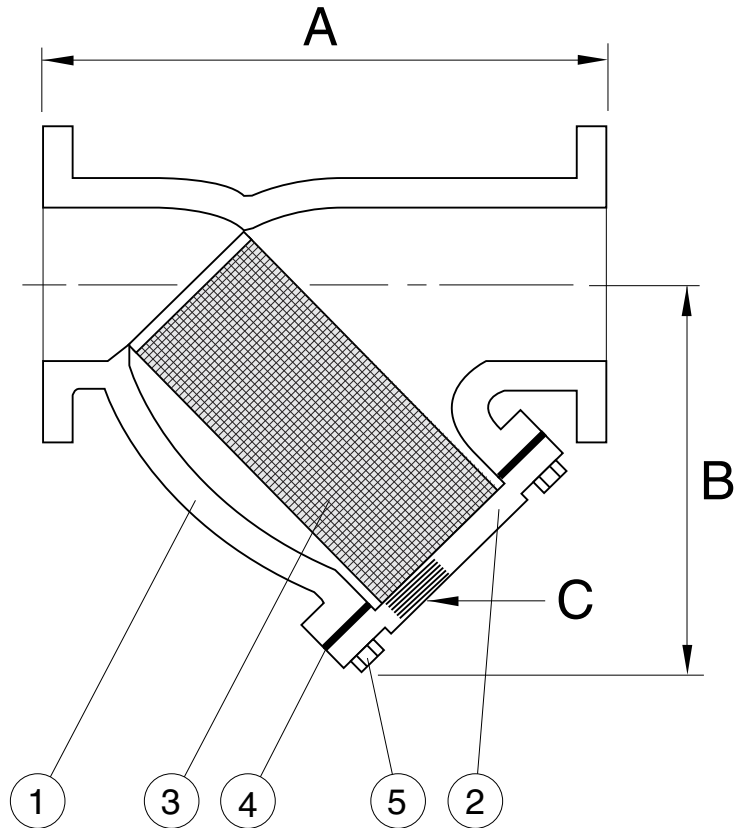

MATERIAL SPECIFICATIONS			
NO.	PART	MATERIAL	ASTM
1	BODY	CAST IRON	A126 CLASS B
2	CAP	CAST IRON	A126 CLASS B
3	SCREEN	304 STAINLESS STEEL	
4	GASKET	NON-ASBESTOS	
5	BOLT	CARBON STEEL	

DIMENSIONS IN INCHES			
SIZE	A	B	C (NPT)
2"	7.86	5.25	.50
2½"	10.0	6.50	1.0
3"	10.13	7.0	1.0
4"	12.13	8.25	1.50
5"	15.63	11.25	2.0
6"	18.50	13.50	2.0
8"	21.63	15.50	2.0